

International Disaster Reduction Conference(IDRC)

24 - 29 August 2008, DAVOS – Switzerland

Paper Number: 0174

Seismic Vulnerability Assessment of Steel Storage Tanks in Iranian Oil Refineries

By:

N. Hosseinzadeh, Ph. D.

E-Mail: hosseinz@iiees.ac.ir

www.iiees.ac.ir

International Institute of Earthquake Engineering and Seismology (IIEES)
Tehran, Iran

Table of contents:

1. INTRODUCTION
2. TANKS FAILURE MODES
3. ANALYTICAL APPROACH
4. ANALYSES RESULTS
5. VULNERABILITY ANALYSES
6. CONCLUDING REMARKS



Typical storage tanks have been studied in this research
(*Unanchored Cylindrical Steel Liquid Tanks*)

1. INTRODUCTION:

Liquid storage tanks are important components of lifeline and industrial facilities.

Modern oil and liquid fuel storage tanks included in lifeline systems vary from 12 to 76 m in diameter with height that are nearly always less than the diameter.

Ground supported, circular cylindrical tanks are more frequent than any other types because they are simple in design, efficient in resisting primary hydrostatic pressure, and can be easily constructed.

The vulnerability and seismic risk level of above ground liquid tanks are very high. Examples of tank collapses and extensive uncontrolled fires have been observed during the following earthquakes:

1933 Long Beach,
1964 Niigata,
1964 Alaska,
1971 San Fernando, and
1999 Kocaeli.

The large-scale damage to unanchored tanks in recent earthquakes highlighted the need for a careful analysis of such tanks.

The objective of this paper is to evaluate the seismic vulnerability of cylindrical liquid storage tanks of an Iranian oil refinery complex according to International documented standards and guidelines such as:

API650,1998&2005, and ASCE, 1994.

Also, refined finite element analyses (FEM) is used in order to vulnerability evaluation and retrofit design of studied tanks.

General information of studied tanks

Tank	Height(H)	Diameter(D)	Density	Yield stress	Height to diameter Ratio
No.	mm	mm	t/m ³	Kg/cm ²	(H/D)
1	14640	37190	0.75	2400	0.39
2	14640	31100	0.75	2400	0.47
3	12810	24380	0.75	2400	0.53
4	11920	18980	0.75	2400	0.63
5	14640	14640	0.75	2400	1.00

2. TANKS FAILURE MODES

The main failure modes of cylindrical above ground tanks includes:

1. Overturning
2. Elastic buckling
3. Sliding
4. Elasto-Plastic buckling (Elephant foot buckling)
5. Roof damage
6. Uplift
7. Different settlement

Results of the past earthquakes:



Uncontrolled fire in oil tanks after earthquake



Situation of tanks after fire



Tank shell

Elephant foot buckling in tanks



Roof damage in tanks due to liquid slashing

3. ANALYTICAL APPROACH

Main assumptions considered in analytical models are as follows:

- refined analytical models is considered for seismic vulnerability evaluation of tanks based on FEM method.
- fluid elements and fluid-structure interaction is considered in analyses.
- shell and beam elements are used for tank shell and structure.
- Linear elastic small deformation analysis is performed for modal analysis.
- The number of modes considered in spectral analysis is based on achievement of 90% seismic structural mass.
- Nonlinear analyses is considered in dynamic analyses.

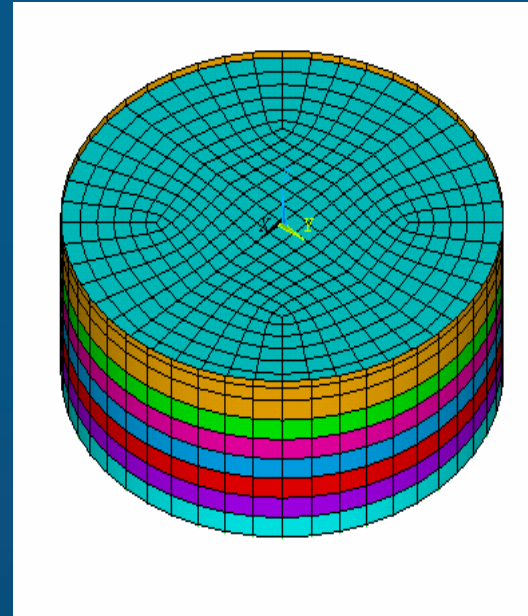
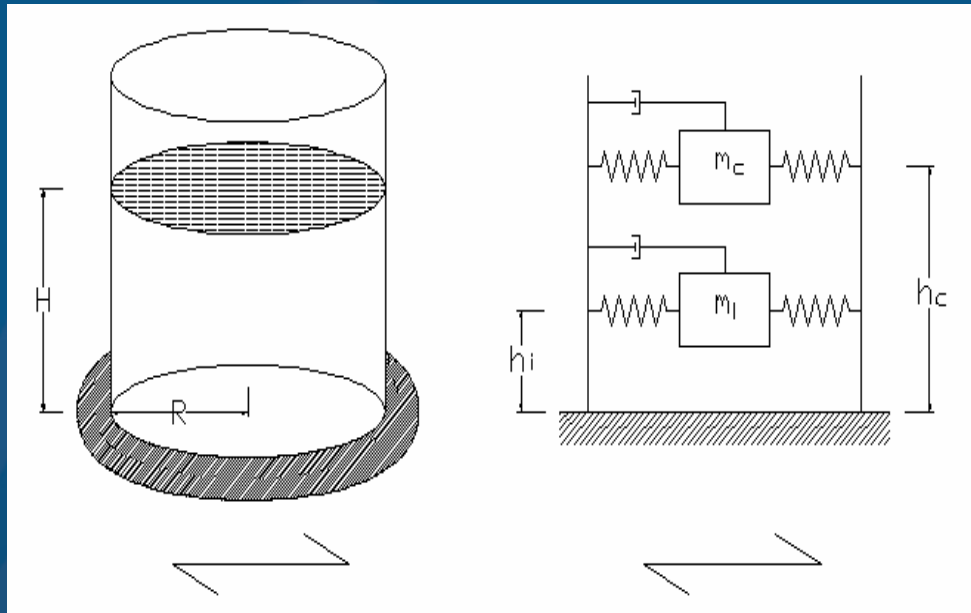

General tank view

Simple model

Refined model

Simple and refined models of liquid-filled tanks

m_i : impulsive mass
 m_c : convective mass

Dynamic analyses:

3.1 Spectral analyses (linear)

Site specific spectra

3.1 Time history analyses (nonlinear)

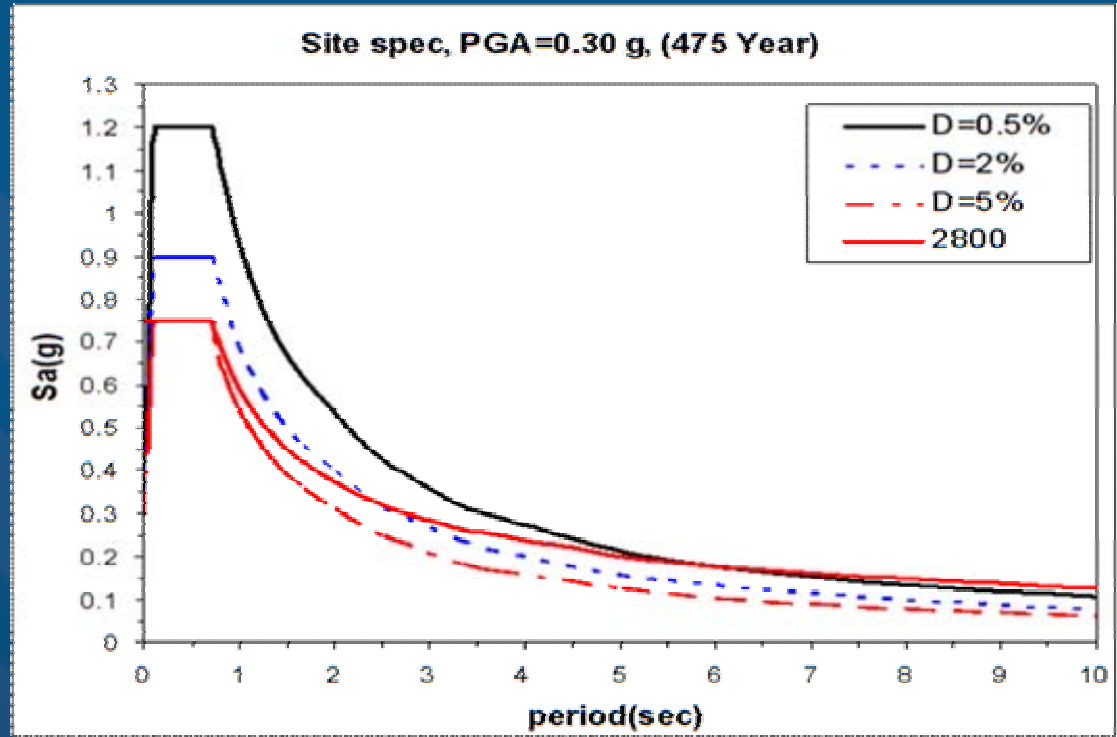

Tabas

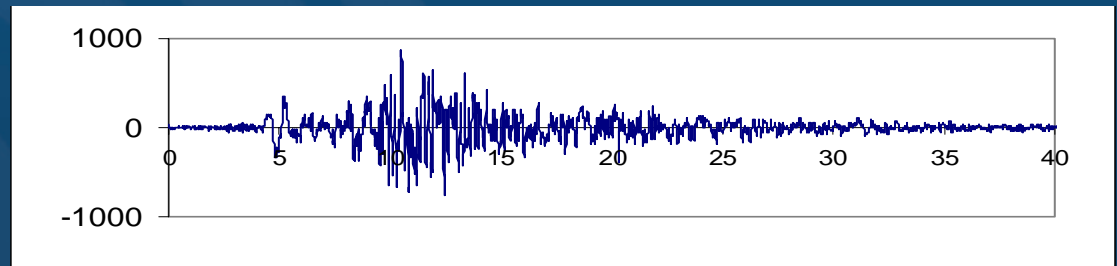

Elcentro

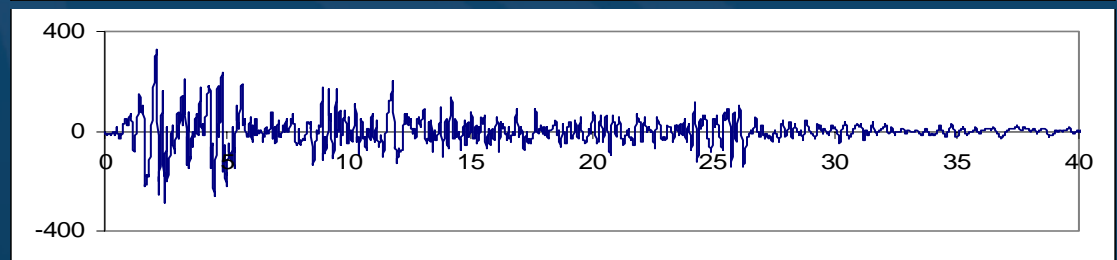

4. ANALYSES RESULTS

Sample Modal Analyses Results:

Mode Shape	Impulsive	Convective	Vertical
Frequency (Hz)	4.0	0.17	4.5

These values are consistent with the theoretical analyses (Haroun) .

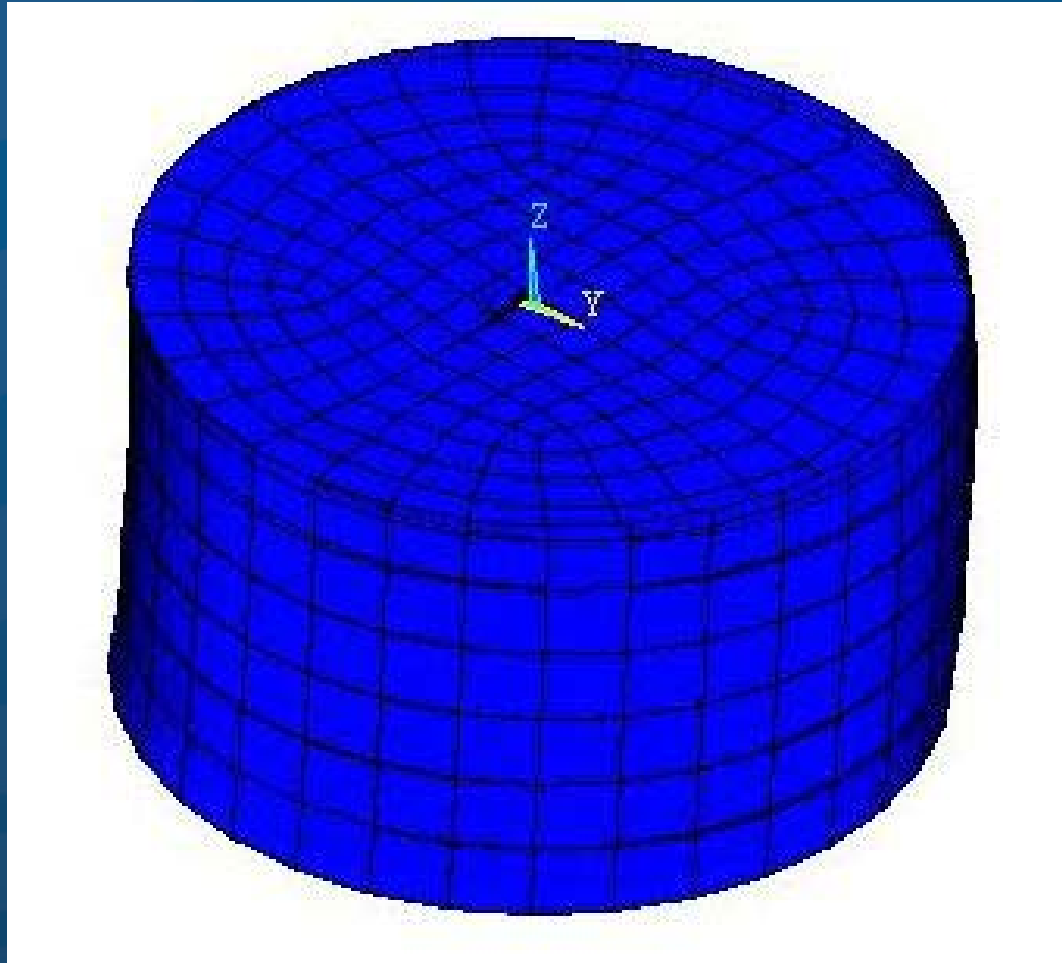

a) Impulsive mode (4.0 Hz)
(reason for uplift)

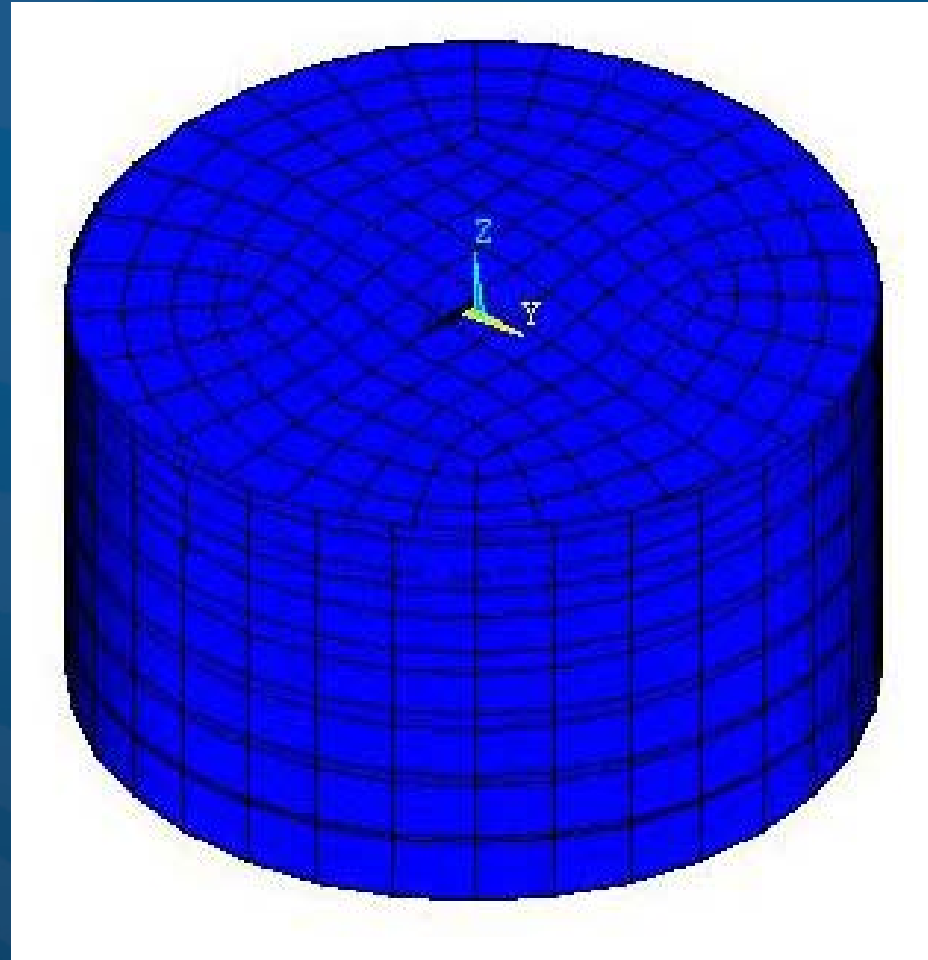

b) Convective mode (0.17 Hz)
(reason for roof damage)

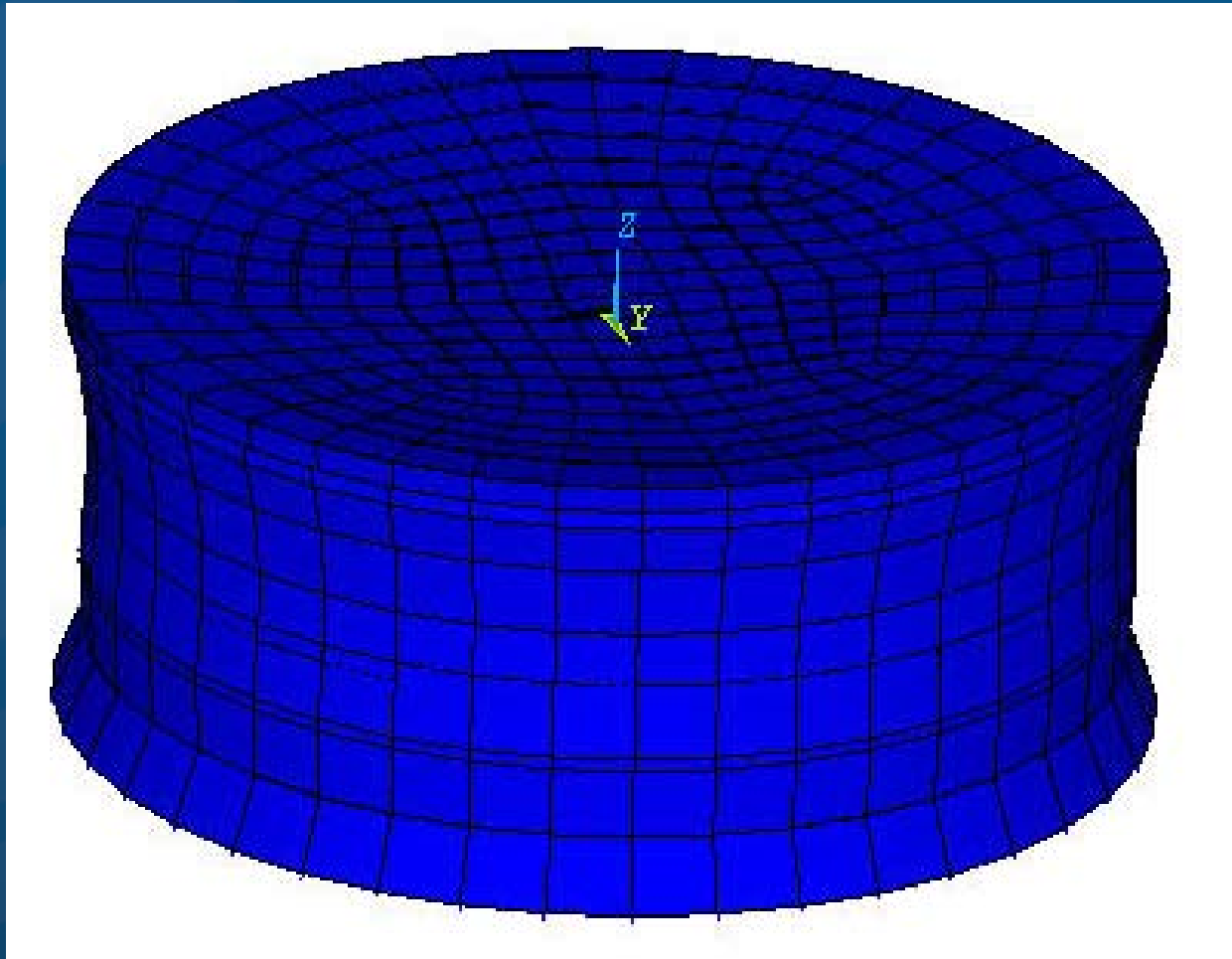

c) Vertical mode (4.5 Hz)
(reason for annular stresses)

Hydrostatic pressure: (Shell stresses)

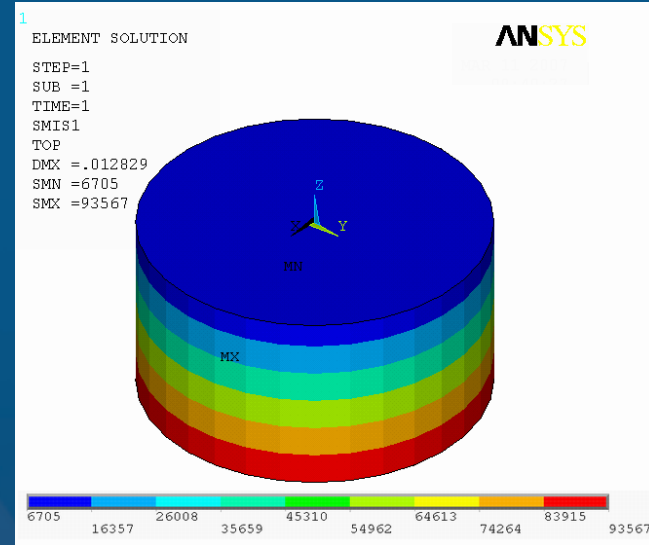

Dynamic analyses:

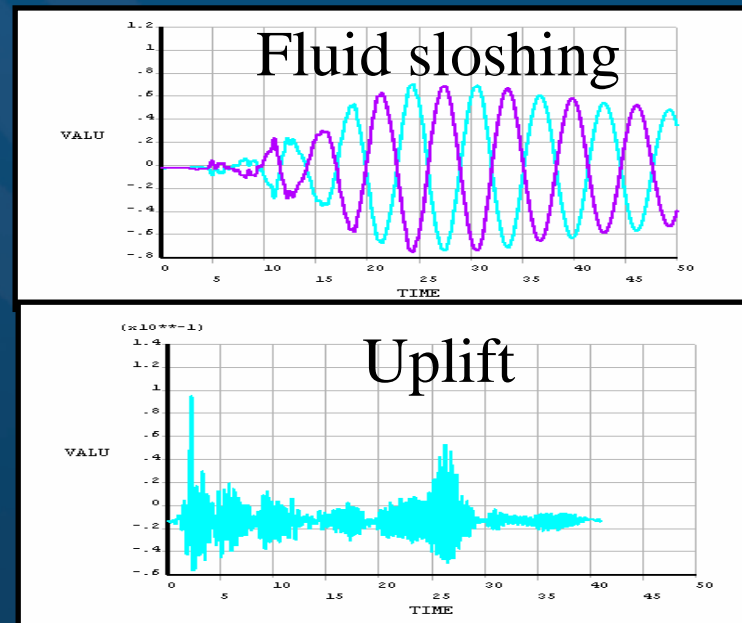

1. Overturning Mode

Tank No.	Calculated Value	Allowable Value	Result
1	0.961	1.57	Safe
2	1.12	1.57	Safe
3	0.55	1.57	Safe
4	1.17	1.57	Safe
5	1.96	1.57	Vulnerable

2. Elastic Buckling Mode

Tank No.	Calculated Value	Allowable Value	Result
1	3.69	24.86	Safe
2	5.73	37.36	Safe
3	12.16	32.34	Safe
4	7.69	39.39	Safe
5	-	-	-

3. Elephant foot buckling Mode

Tank No.	Calculated Value	Allowable Value	Result
1	172	226	Safe
2	165	226	Safe
3	159	226	Safe
4	160	226	Safe
5	118	226	Safe

4. Sliding Mode

Tank No.	Calculated Value	Allowable Value	Result
1	23.14	45.78	Safe
2	15.63	31.97	Safe
3	8.45	18.53	Safe
4	7.41	9.69	Safe
5	4.89	7.15	Safe

5. Sloshing Mode (Roof damage)

Tank No.	Calculated Value	Allowable Value	Result
1	2.32	0.64	Vulnerable
2	2.31	0.64	Vulnerable
3	2.78	0.55	Vulnerable
4	1.72	0.55	Vulnerable
5	1.58	0.64	Vulnerable

6. Uplift Mode

Tank No.	Calculated Value	Allowable Value	Result
1	1.4	30	Safe
2	2.4	30	Safe
3	19.0	30	Safe
4	6.5	30	Safe
5	24.0	30	Safe

7. Different Settlement

Tank No.	Calculated Value	Allowable Value	Result
1	0.0	5.0	Safe
2	0.0	5.0	Safe
3	1.0	5.0	Safe
4	0.3	5.0	Safe
5	1.0	5.0	Safe

5. VULNERABILITY ANALYSES

Average results of studied tanks

No.	Mode of failure	No. of Vulnerable tanks (%)
1	Overturning	20
2	Elastic buckling	-
3	Sliding	-
4	Elephant foot buckling	-
5	Roof damage	100
6	Uplift	-
7	Different settlement	-

This means that Roof damage and Overturning are dominant in the studied tanks

6. CONCLUDING REMARKS:

Seismic vulnerability evaluation of unanchored liquid storage tanks in an oil refinery complex were presented in this paper. Refined finite element analyses method has been used for static and dynamic analyses of 5 different types of tanks in the complex. The following observations can be explained from analytical results:

1. It was observed that the response of tanks was dominated by the uplift mechanism that varied with the intensity and frequency of the input ground motion
2. By increasing the diameter/height ratio, the first sloshing mode period increases and the vulnerability level of tank decreases
3. Tanks with height to diameter ratio greater than 0.7 are unstable with the problem of overturning.

4. Minimum freeboard of tanks should be 10 percent of the tank height to avoid of roof damage during an earthquake.
5. Other failure mechanisms are not dominant in the case studied tanks.
6. Generally, about 50 percent of the existing tanks in the complex are very vulnerable and require retrofitting and strengthening.

However, future research will also permit a greater understanding of the response of other types of tanks under various seismic loadings.

Thanks for Your Attention

For any comments please contact:

N. Hosseinzadeh, Ph. D.

E-Mail: hosseinz@iiees.ac.ir

www.iiees.ac.ir

International Institute of Earthquake Engineering and Seismology (IIEES),
Tehran, Iran