



**Public-private Partnership – Key for Business
Continuity by Integral Risk Management
At IDRC Davos on 27th August 2008**



Dr Rakesh Dubey

Director

Disaster Management Institute

Bhopal

rakeshddubey@hotmail.com



Objective of the presentation

1. Understanding the PPP concept
2. Risk assessment and management
3. Application and integration of 1 & 2 in Business continuity



Is the slide represent an Industry ?





Is this slide also represent an Industry ?





Is it an Industry ? Its Bhopal





Is it Disaster ? Loss of property, lives, environment, disruption of bussiness







Business Continuity Plan

- The ability of an organization to ensure continuity of service and support for its customers and community, etc. and to maintain its viability before, after, and during an event by taking confidence of Local, regional and national governments.
- **Simply :**
The ability to stay in business after a disaster strikes!



BENEFITS OF A CONTINUITY OF OPERATIONS PLANNING PROGRAM

Reduce Disaster *Impact* on the company.

- Plan *Timely* response to loss of business and computing resources.
- Provide a *Reliable* Source of Information to be used at time of Disaster.
- Provide *Clear* understanding of Roles and Responsibilities
- Provide *Ongoing Testing* of all Plans
- Provide *Ongoing Maintenance* of all Plans



Industrial Disaster Management Cycle

Safety Continuum

Prevention

avoiding incidents and lessening impacts, and learning from experience to reduce vulnerability and increase resilience



Preparedness

being alert, ready and trained to act prior to the onset of an accident

Response

managing the consequences of an accident and providing immediate relief, as well as taking steps towards restoring and returning to normality





- 
-
- Disaster Management Planning both on-site and off-site with following components:
 - A. Risk Assessment & Management
 - B. Emergency Preparedness
 - C. Community Dialogue



- 
-
- Disaster Impact Assessment
 - Toxic release, heat fluxes, pressure waves



Risk Assessment & Management

1. evaluate range of potential incidents (without considering possible causes)
2. put mitigation in place for foreseeable ones
3. evaluate community consequences for range of incidents,



a) **credible worst** case

- largest tank or worst failure consequence
- reasonable duration of release
- passive mitigation in effect
- credible worst weather

b) **worst imaginable** case

- largest tank or worst failure consequence
- worst possible duration or release
- no mitigation
- worst possible weather



Reliability Risk Assessment

- Risk Based Maintenance Planning
 - Risk estimation
 - Hazard identification
 - Quantitative Hazard Assessment
 - Probabilistic Hazard Assessment
 - Risk Quantification
 - Risk evaluation
 - Setting up risk acceptance criteria
 - Risk comparison
 - Maintenance planning to run the plant safely
 - Risk treatment: Termination or transfer or acceptance



What would be the impacts?

What may go wrong?

How it may go wrong?
How likely its occurrence?

What maintenance schedule would reduce its likelihood of occurrence?

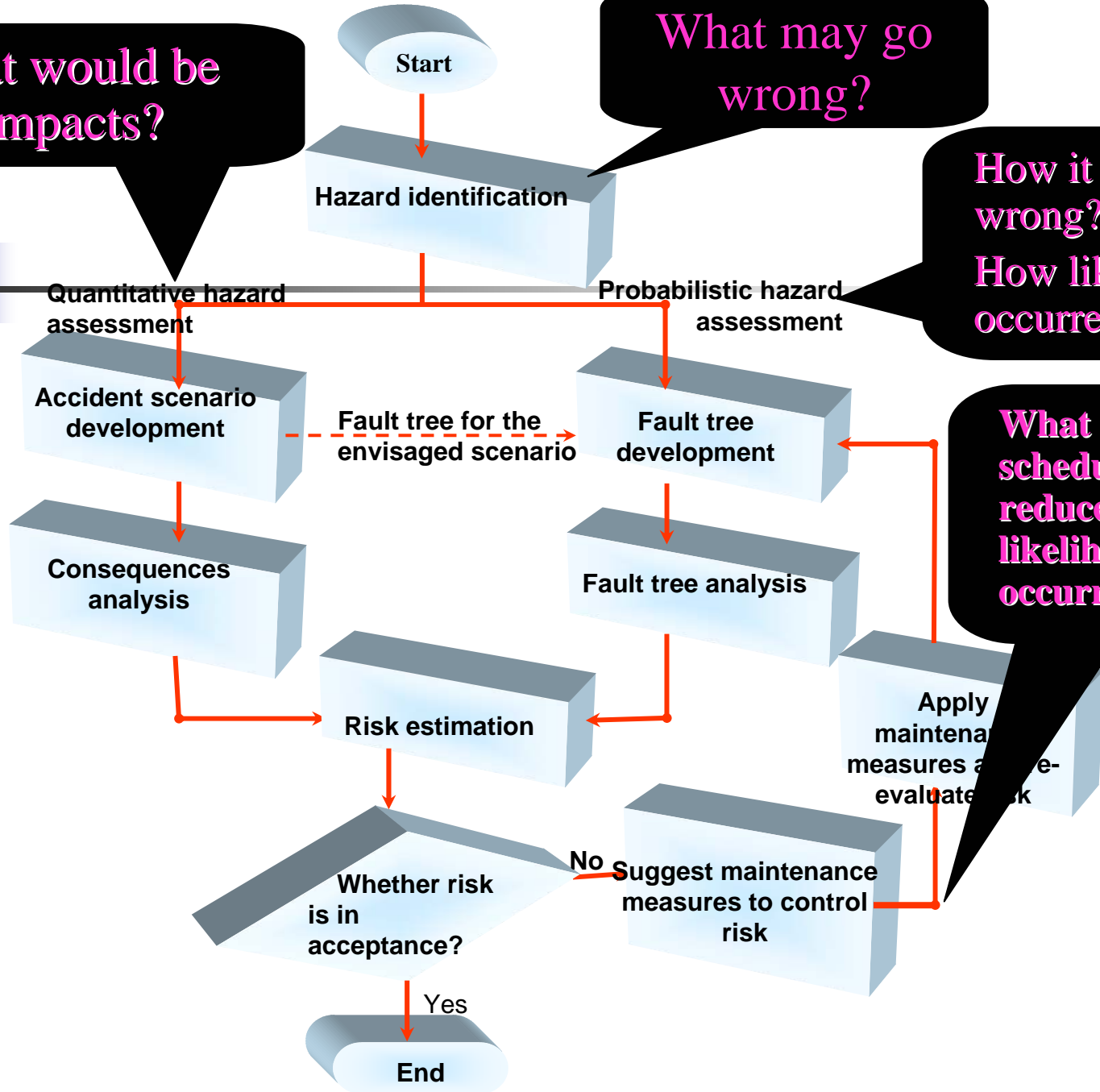

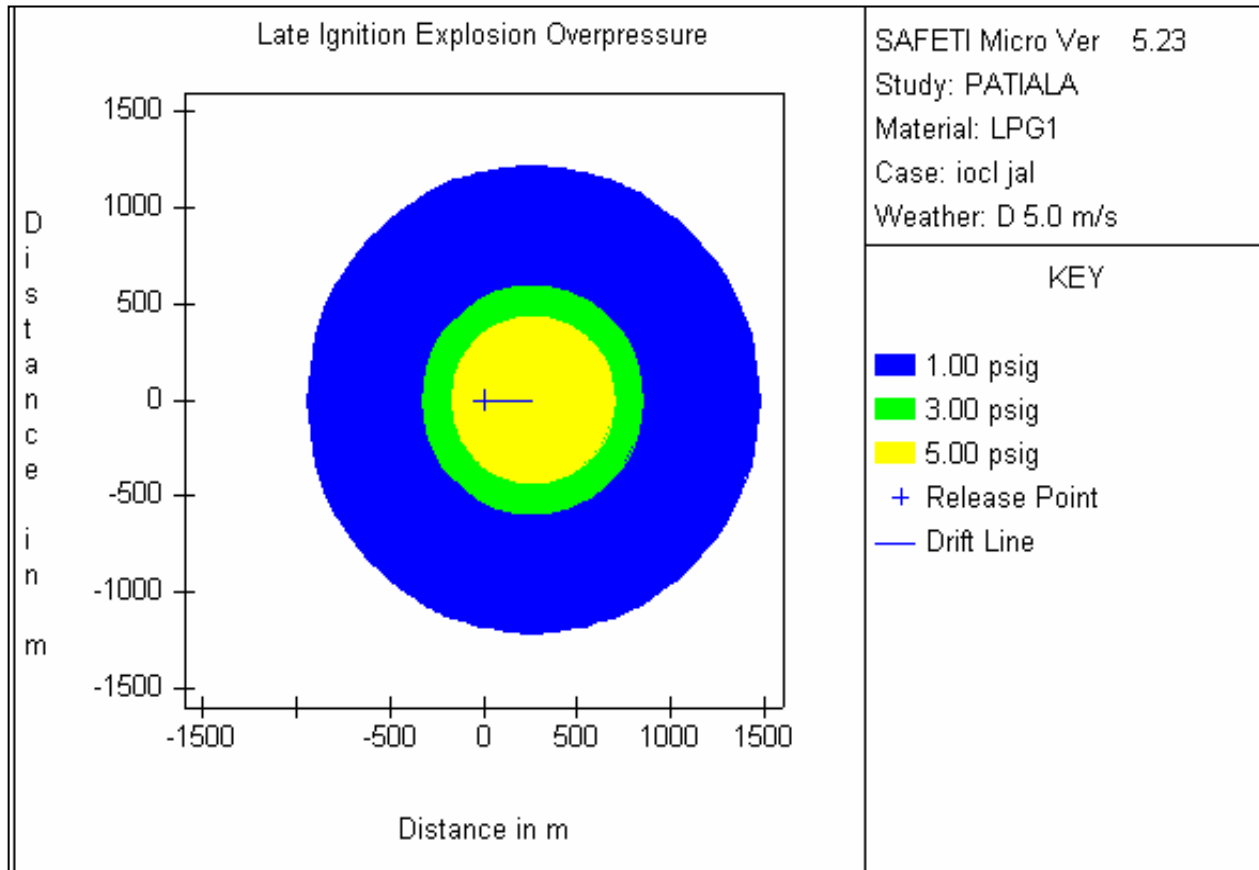
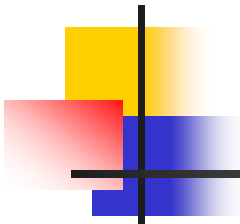

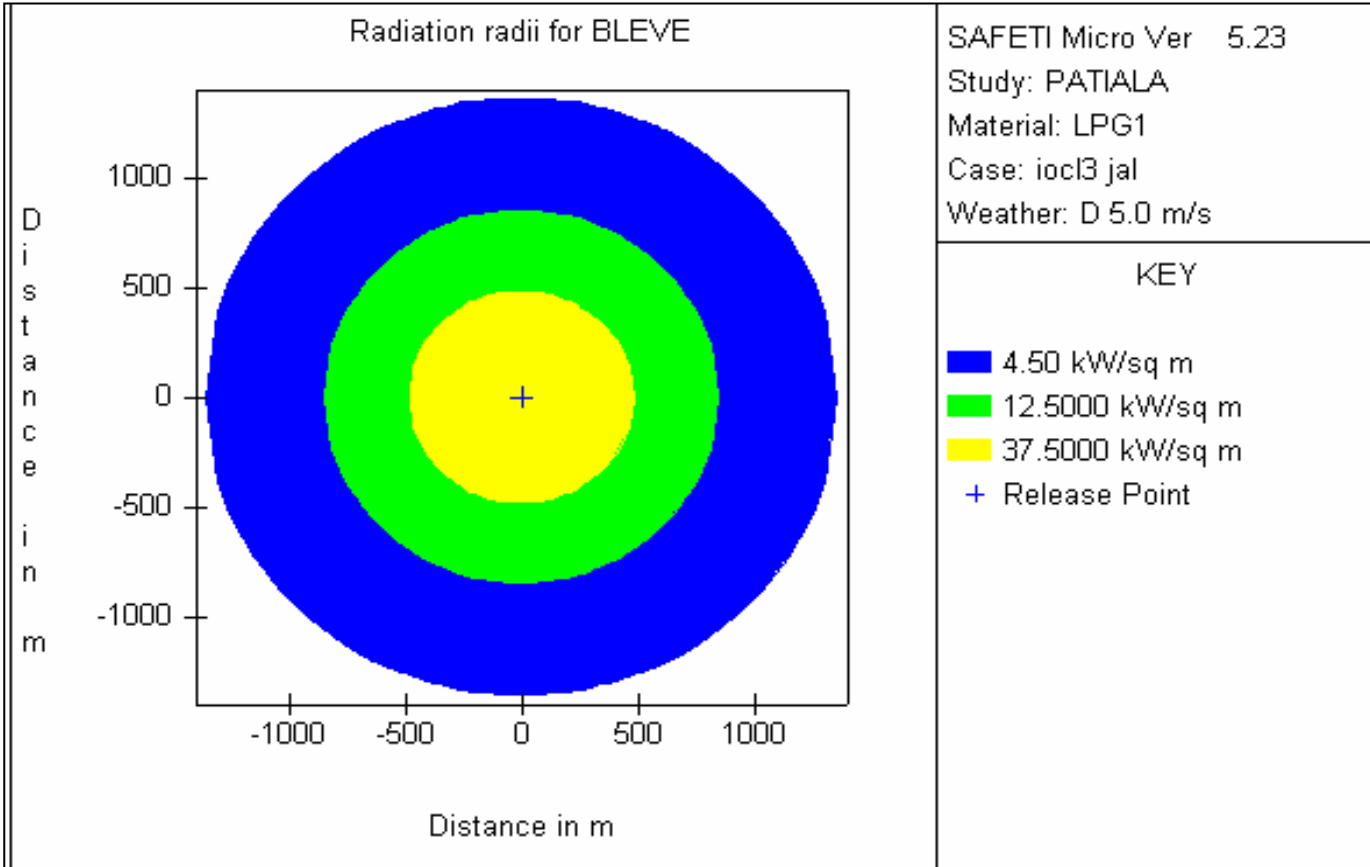
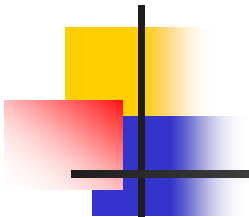

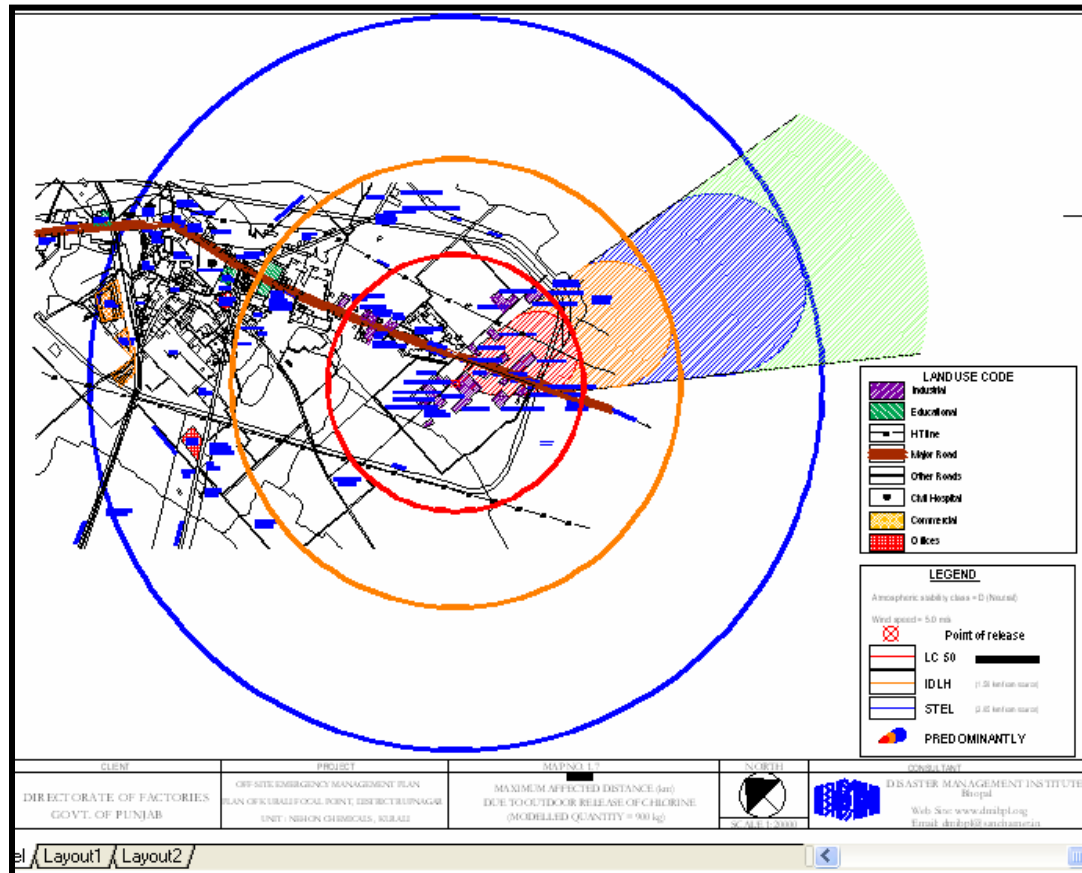

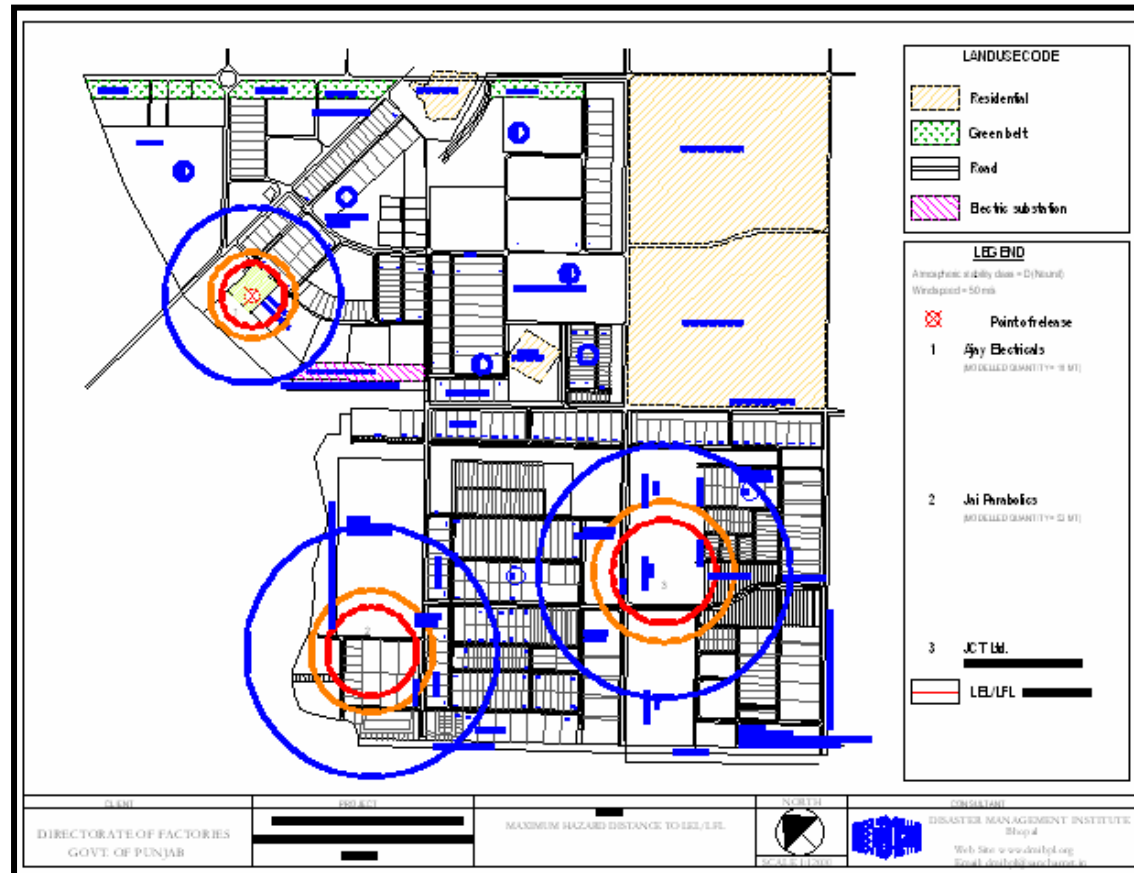

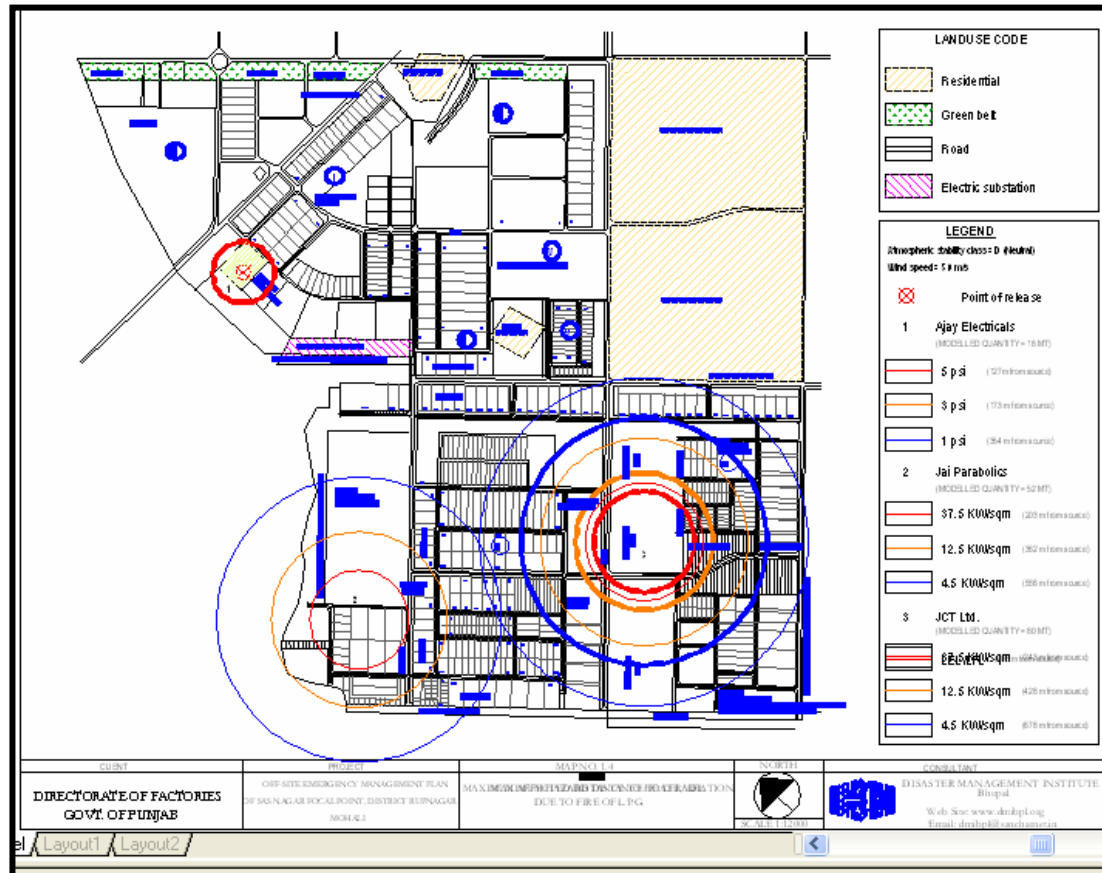

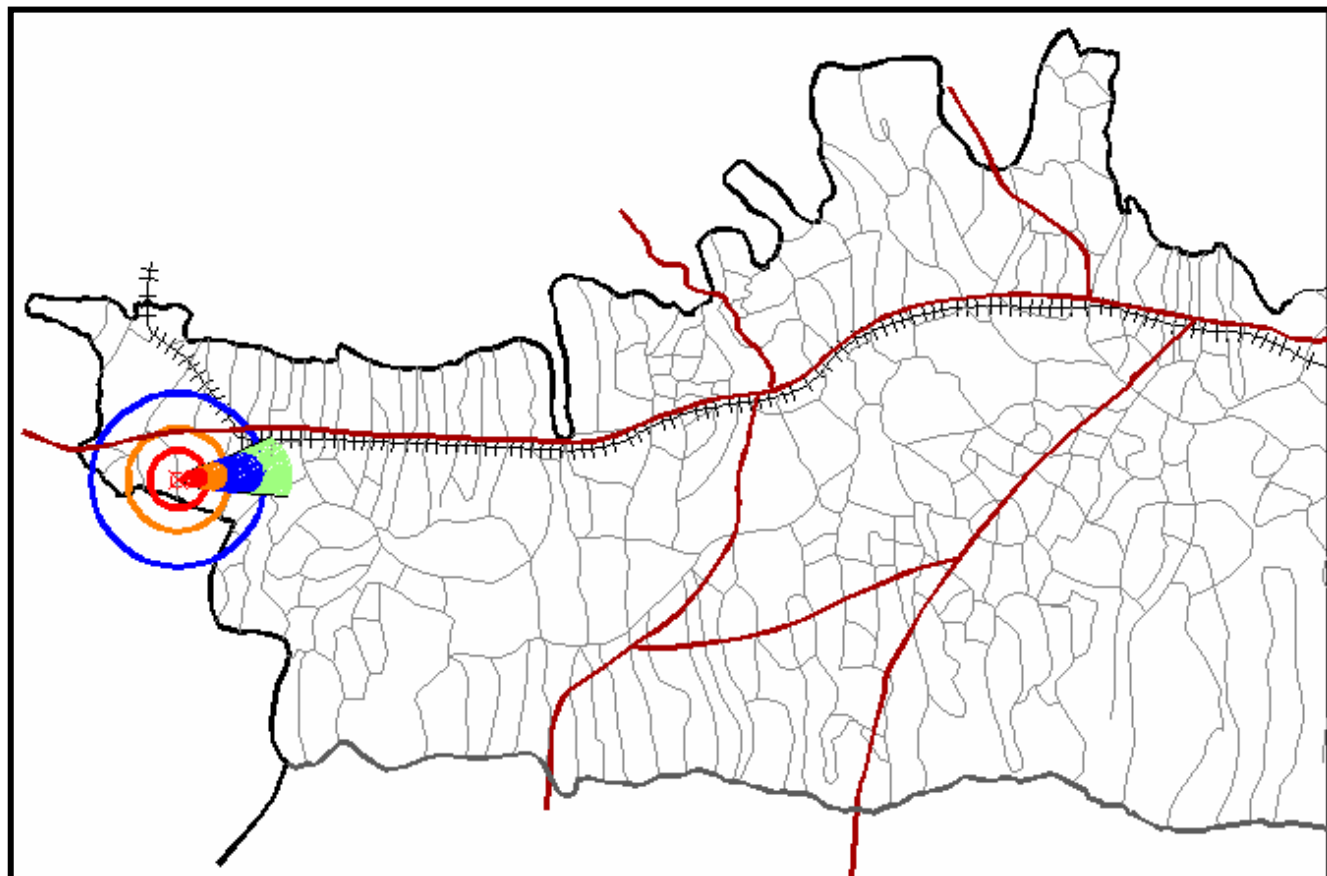
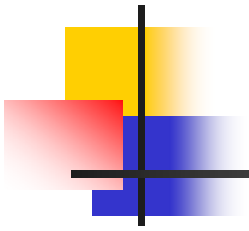

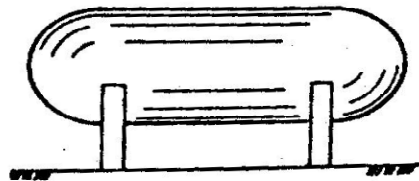

HORIZONTAL CYLINDRICAL TANK

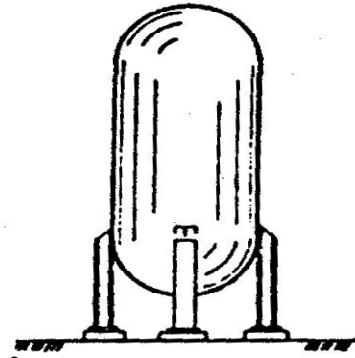

VERTICAL CYLINDRICAL TANK

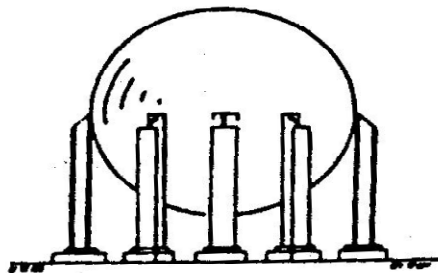

SPHERE

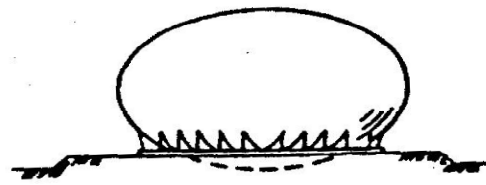

SPHEROID

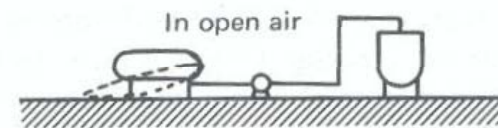
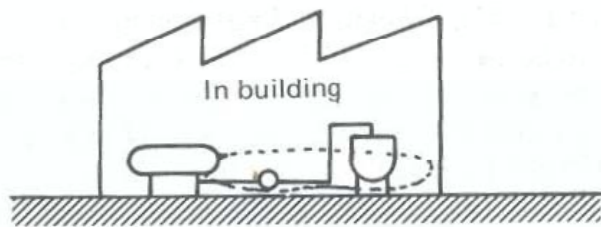

(d)

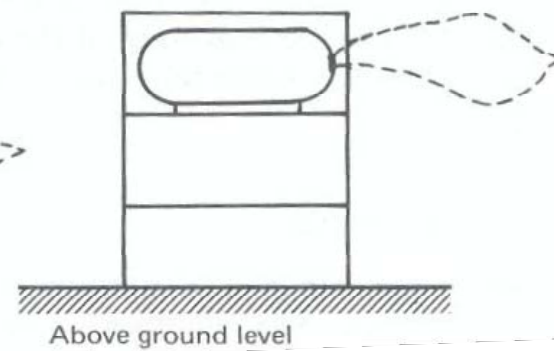
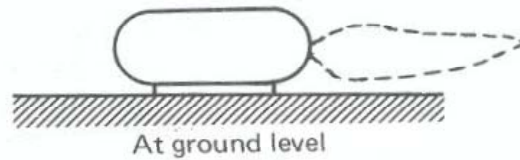
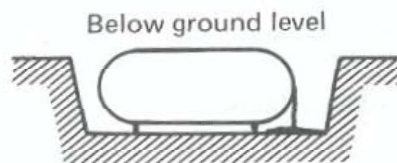

(e)

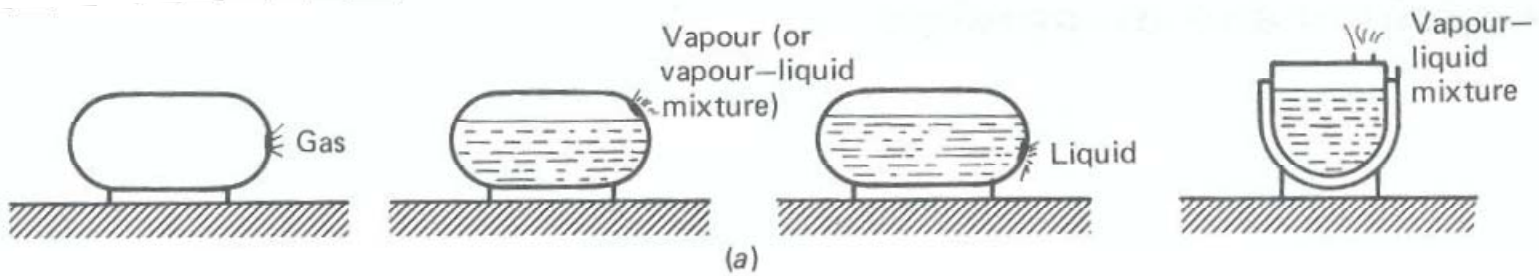

(b)

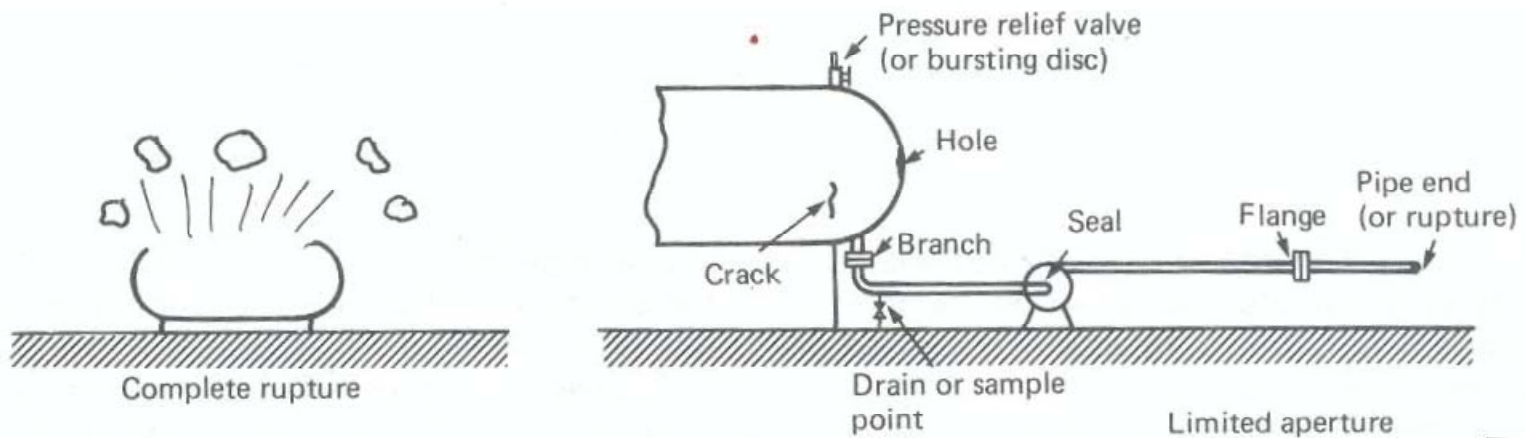

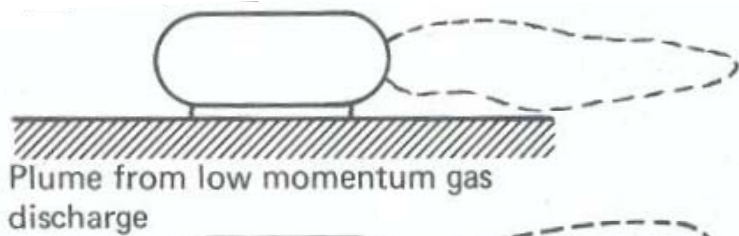

Plume from low momentum gas discharge

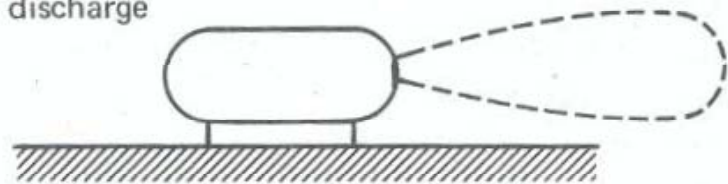

Turbulent momentum jet from high momentum gas discharge

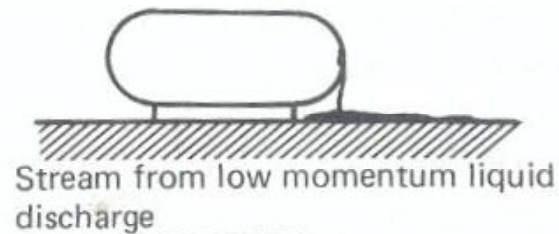

Stream from low momentum liquid discharge

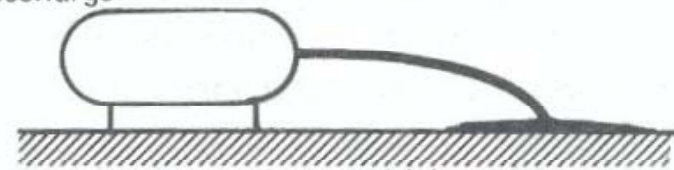

High 'throw' jet from high momentum liquid discharge

(f)



- **Preparedness, Planning, Response**



Layer of Protection Analysis

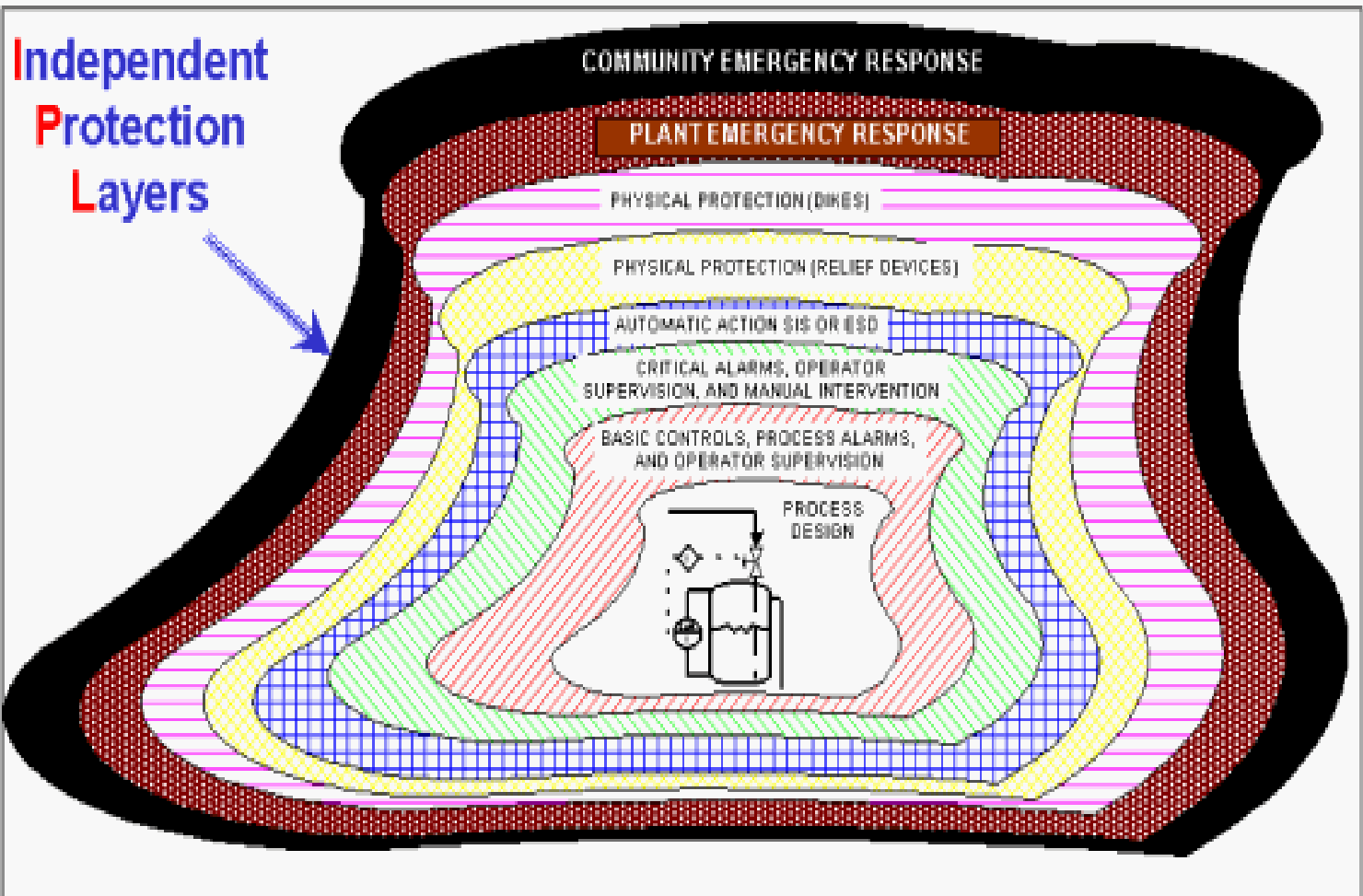



ALARP

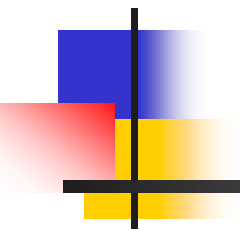



ALARP means

‘As Low As Reasonable Practicable’

ALARP demonstration means:

To demonstrate that the project & associated systems and HSEMS will enable the facility to be operated & maintained safely such that residual risks to HSE are tolerable



Conclusion

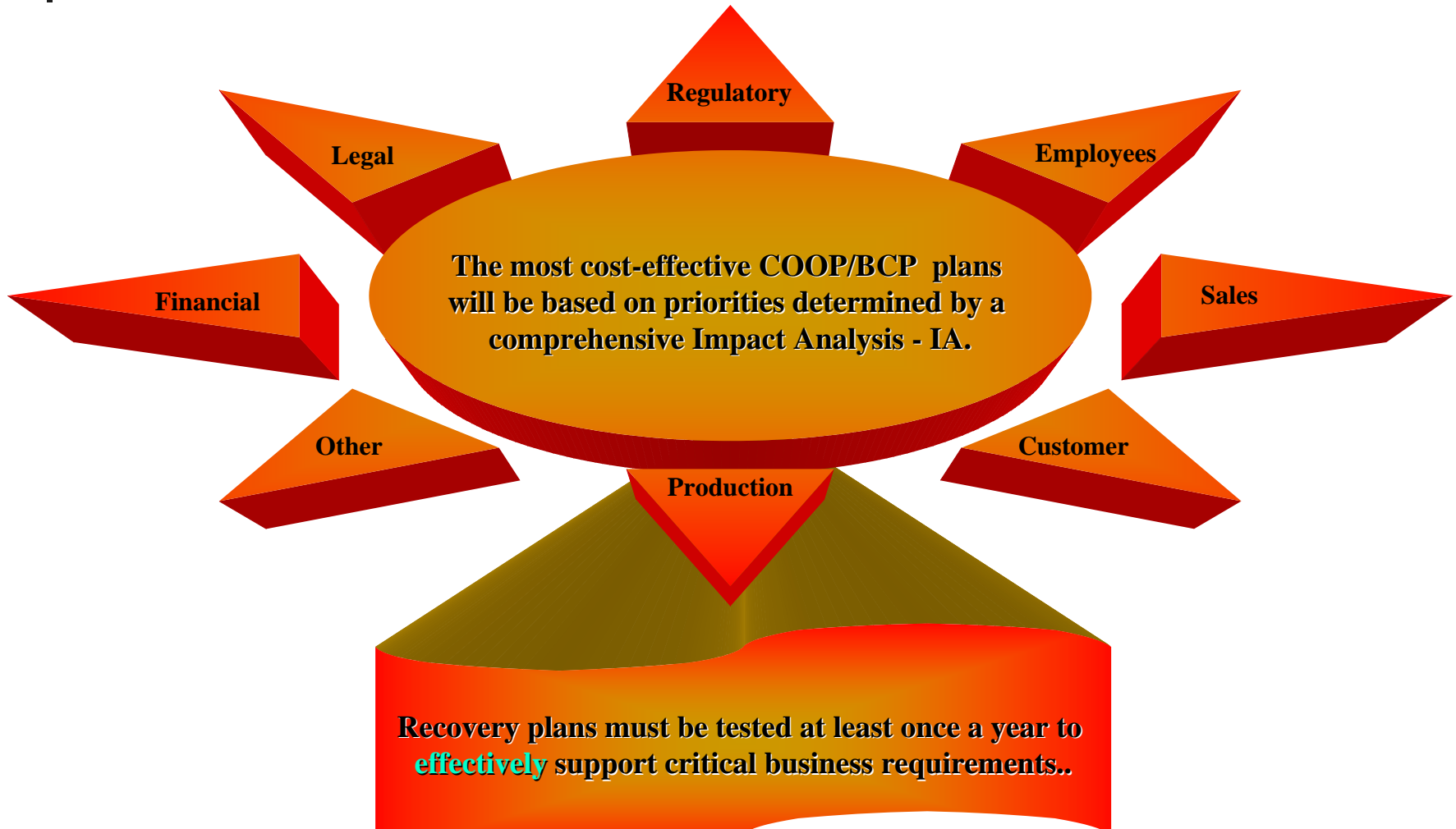

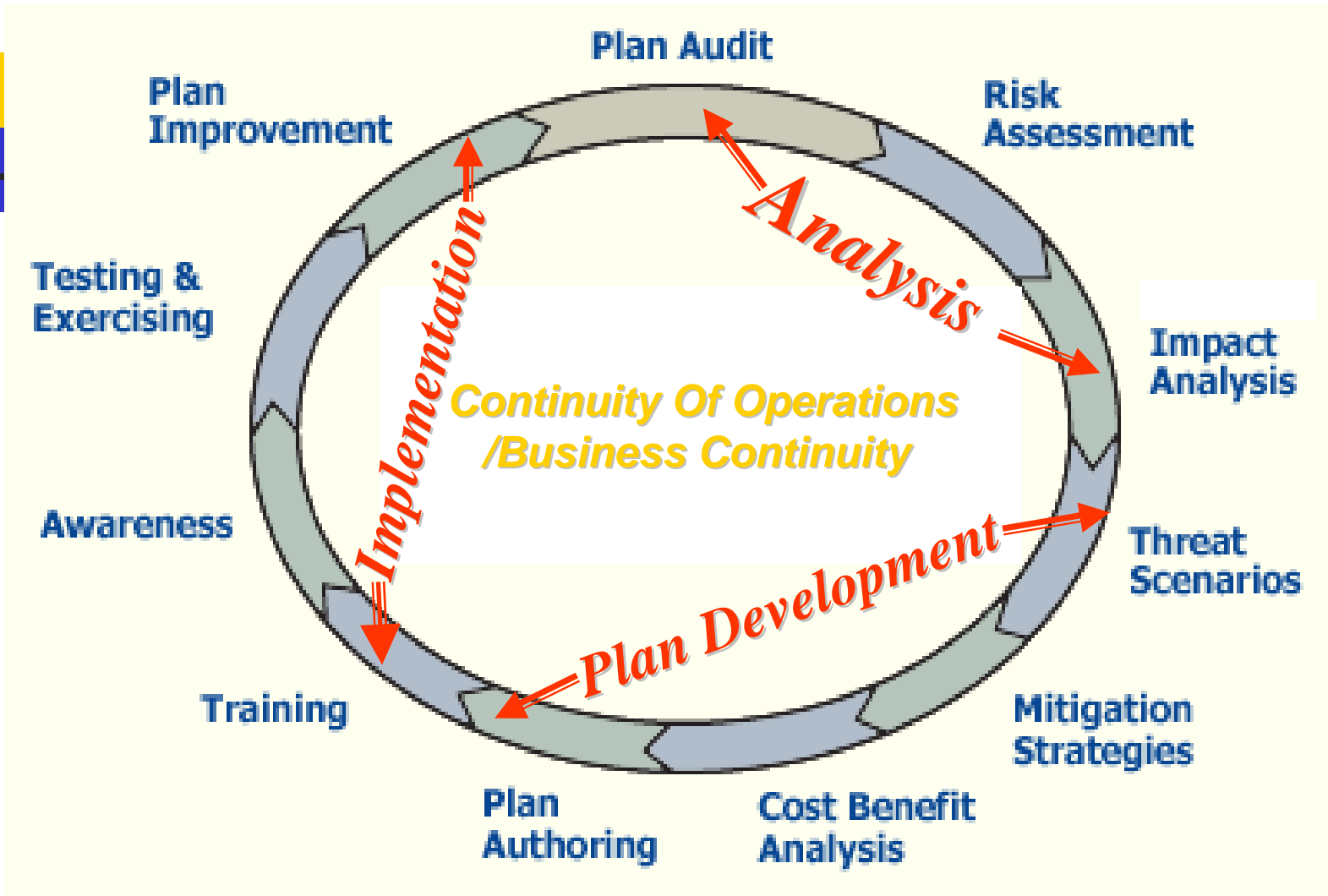

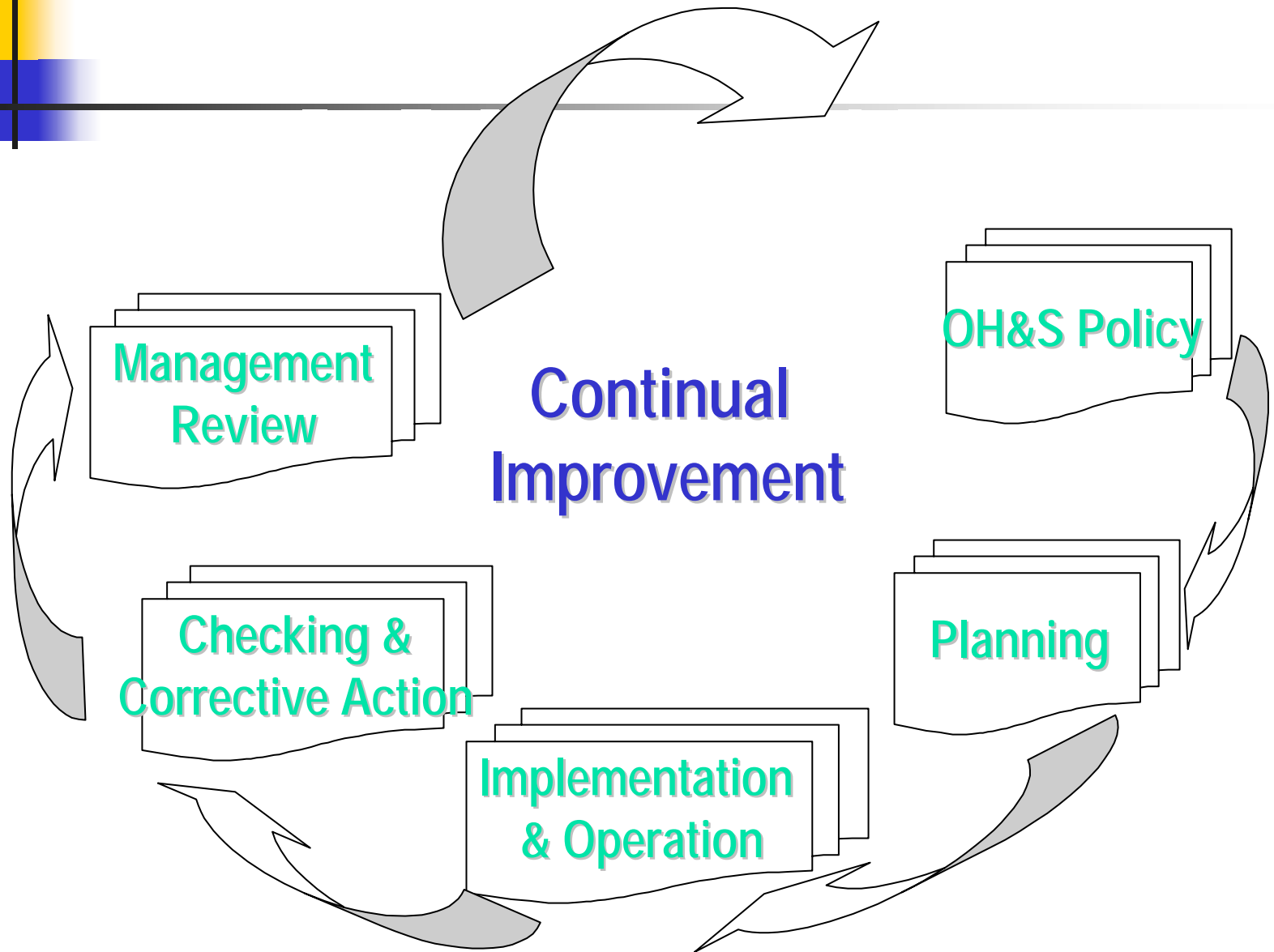
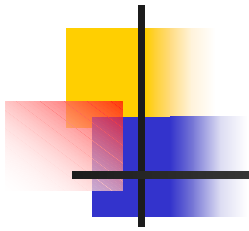

Continual Improvement

Management Review

OH&S Policy

Planning

Implementation & Operation

Checking & Corrective Action



??

If,

A	B	C	D	E	F	G	H	I	J	K	L	M	N	O	P	Q	R	S	T	U	V	W	
X	Y	Z																					

Equals,

1	2	3	4	5	6	7	8	9	10	11	12	13	14	15	16	17	18	19	20	21	22	23	
24	25	26																					

Then,

$$K + N + O + W + L + E + D + G + E = 96\%$$

$$11 + 14 + 15 + 23 + 12 + 5 + 4 + 7 + 5 = 96\%$$

$$H + A + R + D + W + O + R + K = 98\%$$

$$8 + 1 + 18 + 4 + 23 + 15 + 18 + 11 = 98\%$$

Both are important, but the total falls just short of 100%

But,

$$A + T + T + I + T + U + D + E = 100\%$$

$$1 + 20 + 20 + 9 + 20 + 21 + 4 + 5 = 100\%$$

Safety really is about attitude. Make 100% Safe Behavior your choice both ON and OFF the job

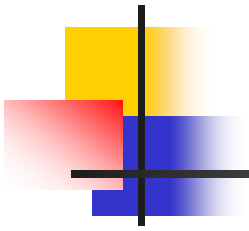
- 
-
- With the support of InWEnt- Germany we are launching a programme of Capacity development in iDRM (industrial Disaster Risk Management)
 - Kindly read the Risk Wise

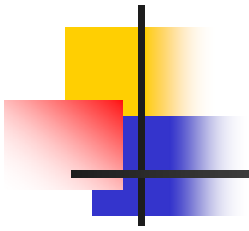

Thanks